

MOTORCYCLES



Valentin and Marco
PLTW
Period 1





**GOTTLIEB DIAMLER CREATES THE
FIRST GAS ENGINE POWERED
MOTORCYCLE. 1885**



HILDEBRAND AND WOLFMULLER CREATED
THE FIRST SERIES PRODUCTION
MOTORCYCLE. 1894

- BMW MOTORRAD WAS INVENTED BY BMW.
- THIS BIKE HAS A BOXER ENGINE.
 - A BOXER ENGINE HAS HORIZONTALLY-OPPOSED PISTONS.
- TYPICALLY, THE LAYOUT HAS TWO CYLINDERS ARRANGED ON TWO BANKS ON EITHER SIDE OF A SINGLE CRANK SHAFT AND IS KNOWN AS THE BOXER, OR HORIZONTALLY OPPOSED ENGINE

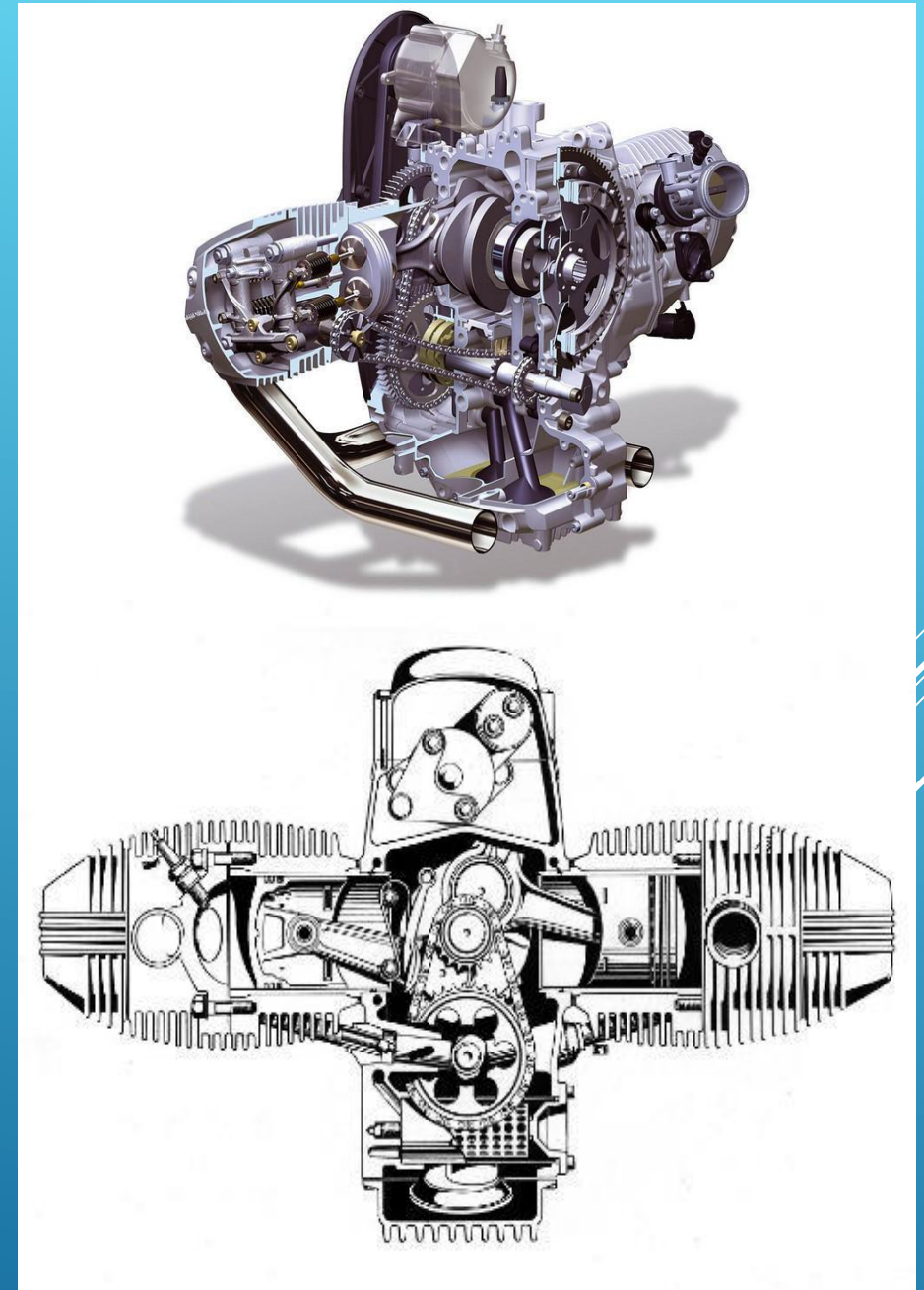

- NEXT, IN 1935 THE BMW CAME OUT WITH THE HYDRAULIC SUSPENSION FORK.
 - THE HYDRAULIC SUSPENSION FORK IS LIKE A SPRING THAT WHEN YOU WOULD HIT THE FLOOR, YOU WOULD BOUNCE UP, WHICH WOULD PREVENT YOU FROM GETTING HURT.

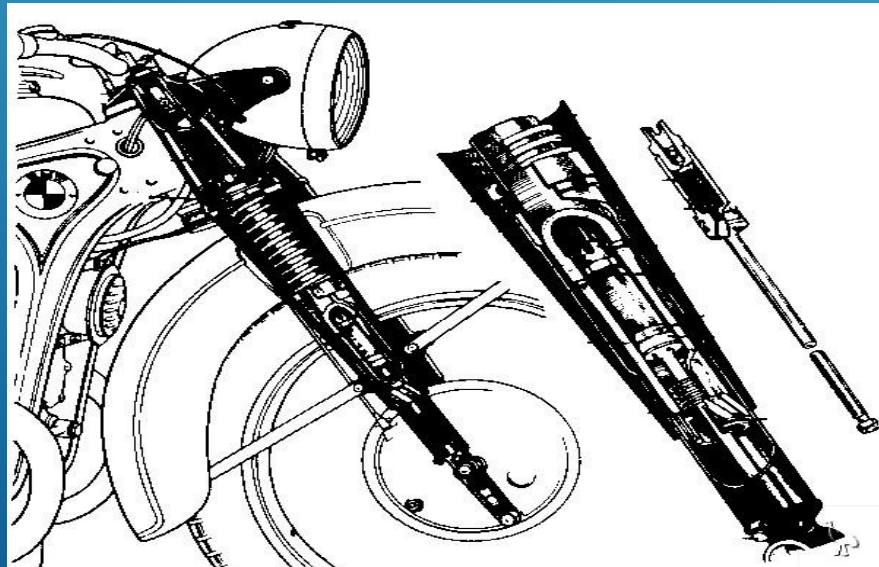



- IN 1978, CHARLES W. LINDQUIST MADE A MOTOR CYCLE GEAR SHIFTER THAT WOULD ALLOW CYCLISTS TO SLIP THEIR SHOE INTO SHIFTING POSITIONS .

- THIS WOULD HELP THE DRIVER CHANGE MODES .

- FOR EXAMPLE, IF THEY'RE GOING ON A BUMPY UPHILL ROAD, THEY WOULD CHANGE THE MODE FOR THE BIKE TO GO FASTER .

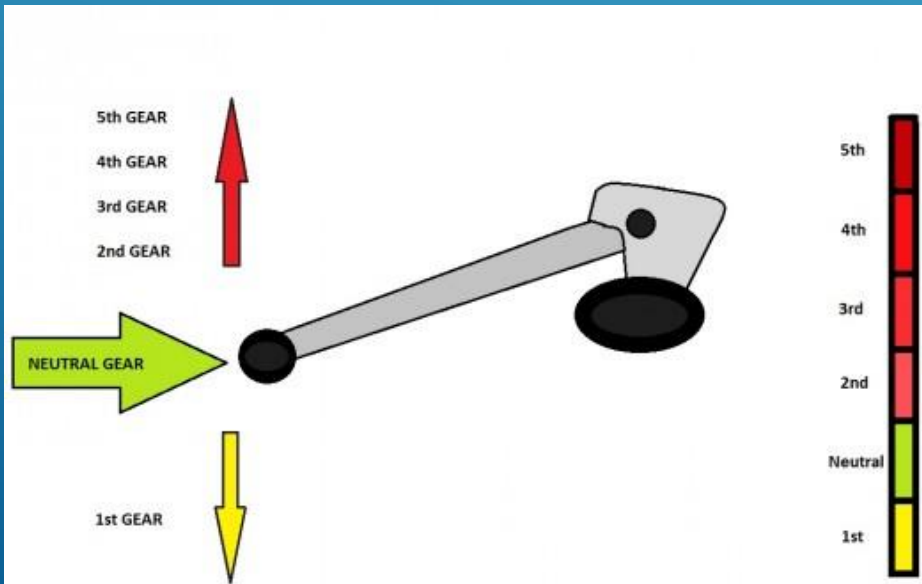

- IN 1995, THE YAMAHA MOTORCYCLE WAS AN IMPACT BECAUSE IT HAD MORE CC'S THAN ANY BIKE AT THE TIME.
 - CC'S ARE CUBIC CENTIMETERS .
 - A CC IS 0.39 OF AN INCH .
 - THE MORE CC'S THERE WOULD BE THE BIGGER THE MOTOR, AND THE BIGGER THE MOTOR THE FASTER IT WOULD BE.

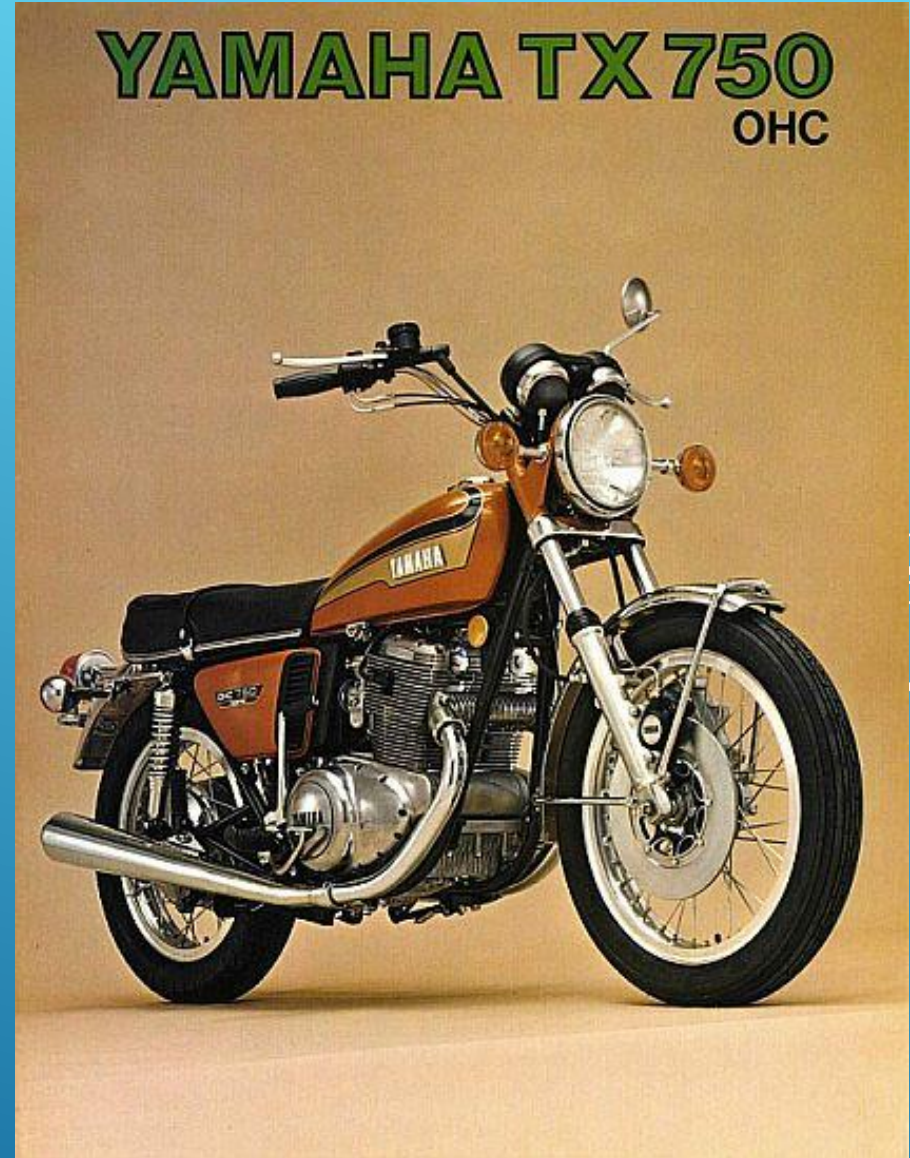



- IN 2012, THE BRAMMO EMPLUSE MOTORCYCLE WAS EQUIPPED WITH A WATER COOLED ELECTRIC MOTOR, NEVER DONE BEFORE ON ELECTRIC BIKES.
- THIS IS BENEFICIAL BECAUSE IT PREVENTS OVERHEATING. THE WATER ACTS AS A COOLING DEVICE FOR THE ENGINE.



THANK YOU VERY MUCH.
THIS IS THE END OF THE PRESENTATION.
ANY QUESTIONS?