

**FRANKLIN LAKES BOARD OF EDUCATION
FRANKLIN LAKES, NEW JERSEY**

REORGANIZATION MEETING AGENDA

Tuesday, January 06, 2015

Franklin Avenue Middle School
755 Franklin Avenue, 8:00 PM
Multi-Purpose Room

1. CALL TO ORDER BY THE PRESIDENT, PRO TEM

2. FLAG SALUTE

3. PUBLIC ANNOUNCEMENT

The New Jersey Open Public Meetings Law was enacted to insure the right of the public to have advance notice and to attend the meetings of public bodies at which any business affecting their interests is discussed or acted upon. In accordance with the provisions of the Act, the Franklin Lakes Board of Education has caused notice of this meeting to be published by having the date, time, and place thereof posted on the School website; published in the Board's designated newspapers: *The Ridgewood News* and *The Record*; and mailed to all persons, if any, who have requested said notice.

4. ROLL CALL

5. ELECTION RESULTS

	<u>Votes</u>
3-year terms: Peter Koulikourdis	1,154
Susan McGowan	1,140
Jennifer Marcus	1,085
Vicki Holst	1,080
Larry Loprete	1,050
Randy Dixon	978

6. ADMINISTER OATH TO NEWLY ELECTED BOARD MEMBERS

7. NOMINATIONS FOR PRESIDENT

Motion to approve nomination

8. NOMINATIONS FOR VICE-PRESIDENT

Motion to approve nomination

9. NEWLY ELECTED PRESIDENT ASSUMES OFFICE

10. CALL FOR MOTIONS ON THE FOLLOWING ITEMS UNTIL DECEMBER 31, 2015:

1. Establish day of official meetings
2. Adopt meeting schedule for year
3. Implement approved 2014-15 school budget
4. Adopt the educational program as per NJAC 6:8-3.5(a)
5. Adopt the current Board Policy Manual

6. Approval of organization chart
7. Approve existing curriculum and textbooks for 2014-15
8. Establish fee for copies of public documents at .5 cents per page
9. Approve CAPITAL ONE BANK as the depository for school funds and the check signatories, as identified
10. Approve AXA Equitable, Valic, Tax Deferred Services, Franklin Templeton, Life Insurance Company of the Southwest (LSW) and Lincoln Investment as tax shelter annuity companies.
11. Authorize uniform minimum chart of accounts
12. Approve \$18,700 as tuition for the 2015-16 school year.
13. Approve the petty cash funds as per Board Policy #3451
14. Approve *The Record* and the *Suburban News* as official newspapers
15. Approve parliamentary procedures to follow *Robert's Rules of Order*
16. Approve appointments at the agreed upon rates:

Board Secretary/Business Administrator	Mr. Michael J. Solokas
Custodian of Public Record	Mr. Michael J. Solokas
Public Agency Compliance Officer	Mr. Michael J. Solokas
Security Officer	Mr. Michael J. Solokas
Attorney	Fogarty and Hara
Auditor	Nisivoccia & Co.
School Treasurer	Ms. Nancy Ciavaglia
Insurance Agent	Nathan Lane Agency
Health Plan Facilitator	Brown & Brown Advisors
Right to Know	Rullo & Juliet Associates, Inc
Affirmative Action Officer	Ms. Ann Jameson
Medical Inspector	Dr. Douglas Fenkart
AHERA	Karl & Associates
Architect	DiCara/Rubino
ADA Coordinator	Dr. John Caliso
District Anti-bullying Coordinator	Dr. John Caliso
Section 504 Compliance Officer	Dr. John Caliso
Homeless Liaison	Dr. John Caliso
Substance Awareness Coordinator	Ms. Mary Beth Como
Asbestos Management & PEOSA Officer/Coordinator	Mr. Michael J. Solokas
Indoor Air Quality Designee	Mr. Michael J. Solokas
Integrated Pest Mgmt. Coordinator & IPM Plan	Mr. Michael J. Solokas
Liaison to the Bergen County Prosecutor's	Dr. Lydia E. Furnari

17. Approve the New Jersey School Board Member Code of Ethics as per the attached.

18. Approve upon recommendation of the Superintendent, the appointment of Michael Solokas, Business Administrator/Board Secretary as the District's Qualified Purchasing Agent for the 2014-15 school year and that he be approved to make purchases for the District in accordance with the provisions of statute as cited in 18A:18A-3 (establishment of bid threshold), 18A:18A-4 (bidding requirements) and such other aspects of 18A:18A as may apply to the procurement of equipment, materials or services.

11. ADJOURNMENT

OFFERED BY _____ SECONDED BY _____

Respectfully submitted:

Michael J. Solokas, Board Secretary

**FRANKLIN LAKES BOARD OF EDUCATION
490 Pulis Avenue
Franklin Lakes, New Jersey 07417**

The Franklin Lakes Board of Education at the Regular Business Meeting held on Monday, January 6, 2015 adopted the following schedule of meetings for the 2015 Calendar Year.

REGULAR BUSINESS MEETINGS

8:00 PM, **FAMS** Multi-Purpose Room, 755 Franklin Avenue (with the exception of those noted)

Tuesday, January 6, 2015 Reorganization (8:00 pm)

Tuesday, January 27, 2015

Tuesday, February 10, 2015

Tuesday, February 24, 2015

Tuesday, March 10, 2015

Tuesday, March 24, 2015

Tuesday, April 14, 2015

Tuesday, April 28, 2015

Tuesday, May 12, 2015

Tuesday, May 26, 2015

Tuesday, June 9, 2015, **6:00 PM**

Tuesday, July 28, 2015 **7:00 PM**

Tuesday, August 11, 2015, **7:30 PM**

Wednesday, September 9, 2015, **7:00 PM**

Monday, September 21, 2015

Tuesday, October 13, 2015

Tuesday, October 27, 2015

Tuesday, November 10, 2015

Wednesday, December 2, 2015

Tuesday, December 15, 2015

PRIVATE SESSIONS

Held prior to the Regular Business Meetings at 7:00 PM in the Board Conference Room, 490 Pulis Avenue (with the exception of those noted)

Tuesday, January 27, 2015

Tuesday, February 10, 2015

Tuesday, February 24, 2015

Tuesday, March 10, 2015

Tuesday, March 24, 2015

Tuesday, April 14, 2015

Tuesday, April 28, 2015

Tuesday, May 12, 2015

Tuesday, May 26, 2015

Tuesday, June 9, 2015, **5:00 PM**

Tuesday, July 28, 2015, **6:15 PM**

Tuesday, August 11, 2015

Wednesday, September 9, 2015, **6:15 PM**

Monday, September 21, 2015

Tuesday, October 13, 2015

Tuesday, October 27, 2015

Tuesday, November 10, 2015

Wednesday, December 2, 2015

Tuesday, December 15, 2015

KEY:

FAMS	Franklin Avenue Middle School
-------------	--------------------------------------

Notes:

May be adjusted if State Law required.

- All Regular Business Meetings are scheduled for Tuesdays at 8:00 PM unless otherwise noted.
- All Private Sessions are scheduled for Tuesdays at 7:00 PM unless otherwise noted.

Revised: 12/17/14

FRANKLIN LAKES BOARD OF EDUCATION

Franklin Lakes, New Jersey

FILE CODE: 2121

Exhibit: Organizational Chart

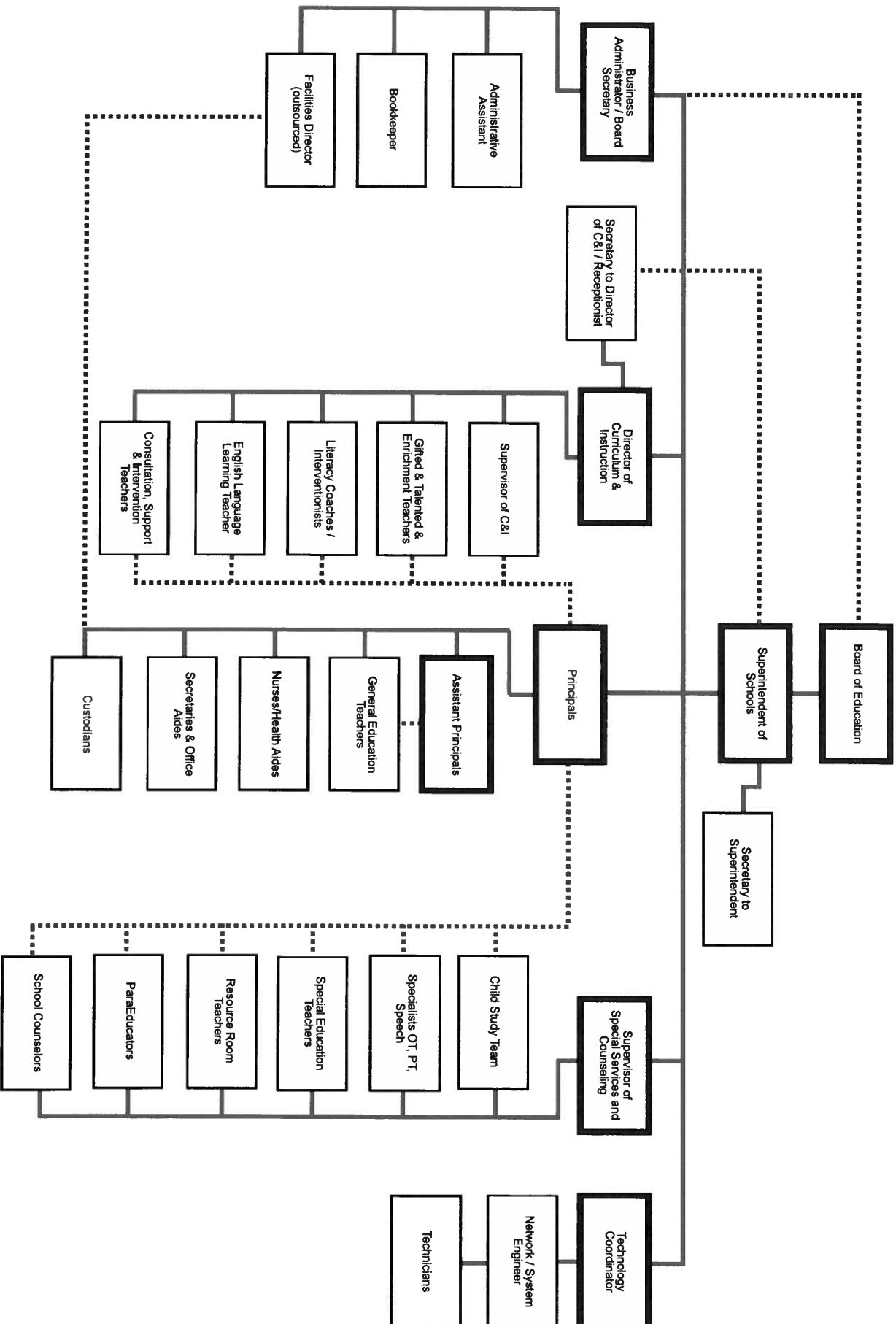



New Jersey School Boards Association

Requirements of the NJ School Ethics Act

ATTENTION PROSPECTIVE SCHOOL BOARD CANDIDATES

Legislation, (P.L. 2011, c.202), signed by Governor Christie on Jan. 17, 2012 gives communities the option to change the date of the annual school board member election to November. Most communities have changed their Annual School Election from April to November. Please check with your local board of education office to confirm the date of the 2014 Annual School Election in your community.

The New Jersey **School Ethics Act** (N.J.S.A 18A:12-21 to 18A:12-33) requires local board of education members to

- File disclosure statements
- Avoid prohibited conduct
- Adhere to the Code of Ethics
- Undergo training in the responsibilities of school board membership

New Jersey administrative regulations (N.J.A.C. 6A:28-1 *et seq* and N.J.A.C. 6A:32-3.2) clarify school board members' responsibilities under the School Ethics Act. The basic requirements, as stated in the Act, are listed below.

DISCLOSURE

Each year by April 30 (or within 30 days after taking office), school officials, including board members, must disclose sources of income and the employment or contractual relationship of relatives with the school district. The disclosure statements are public records, kept by the executive county superintendent and the local school board secretary. The School Ethics Commission has access to the disclosure statements through the county office.

FINANCIAL DISCLOSURE

The Act's financial disclosure provisions require the reporting of only *sources* of income above a certain amount, but not the actual dollar amounts. Board members must report the sources of income for themselves and the members of their immediate families (spouse, and dependent children living in their household).

The financial disclosure statement must include—

- Sources of income exceeding \$2,000 for each family member during the prior calendar year. (Interest or securities income need not be reported unless the family member retains more than 10% of the ownership or control of the financial institution or business organization.)
- Sources of fees and honoraria earned by each family member during the prior calendar year, which totaled more than \$250 from a single source. (Fees and honoraria are payments for such services as personal appearances, speeches or writing.)
- Sources of gifts, reimbursements or prepaid expenses valued at more than \$250 from a single source that were received by each family member during the prior calendar year. (Gifts from relatives need not be reported. Relatives include spouse, children, parents or siblings of the board member.)
- Names and addresses of all business organizations in which

the board member or a member of his or her immediate family had an interest during the prior calendar year. (Interest in a business is defined as ownership or control of more than 10 percent of the profits, assets or stock of the business.)

PERSONAL/RELATIVE DISCLOSURE

The law also requires board members to disclose the following:

- The name and position of any relative (spouse, child, parent, sibling) or person related to the board member by marriage and employed by the school district in which the board member serves.
- The nature of any contract between the district and the board member or his or her relative or person related to the board member by marriage.
- The name of any business that has a contract with the school board and with which the board member or relative has one of the following relationships: (1) The board member or relative is employed by the business; or (2) The board member or relative receives compensation from the business; or (3) The board member or relative has an interest in the business. (Interest in a business is defined as ownership or control of more than 10 percent of the profits, assets or stock.)

PROHIBITED CONDUCT

The School Ethics Act also establishes ethical standards of conduct which serve as guidelines for the activities of school officials, including school board members. The standards are summarized below:

- a. School officials or immediate family members cannot have an interest in any business, or engage in any business, transaction or professional activity that is in substantial conflict with school officials' duties.
- b. School officials cannot use or attempt to use their positions to obtain unwarranted privileges, advantages or employment for themselves or anyone else.
- c. School officials must excuse themselves from any matter in which their objectivity might reasonably be expected to be impaired because of the financial involvement of themselves, an immediate family member, or a business in which they have an interest. School officials must also excuse themselves from any matter where they have a personal involvement that is or creates a benefit to the school official or an immediate family member.
- d. No school official shall engage in any employment or service,

whether compensated or not, which might reasonably be expected to prejudice his or her independence of judgment in the exercise of official duties.

- e. No school official may solicit or accept anything of value if given or offered for the purpose of influencing his or her official actions. This provision also applies to the official's immediate family members and to business organizations in which he or she has an interest. School officials, however, can solicit and accept campaign contributions if they reasonably believe the contributions are not given to influence their official actions.
- f. School officials cannot use or allow the use of their public office or any confidential information for personal financial gain or for the financial gain of either an immediate family member or business with which he or she is associated.
- g. A school official or business organization in which he or she has an interest cannot represent anyone other than the board in any matter pending before the board or involving the board. Labor union representational responsibilities are permitted.
- h. If a school official is a member of a particular group, he or she can vote on a matter that benefits that group so long as he or she is not benefited to a greater extent than other members of that group.
- i. An elected board member can request information for a constituent so long as there is no remuneration attached to the board member or the board member's immediate family.
- j. School officials and immediate family members may represent themselves in any proceeding in the school district that involves their personal (family) interests. (For example, this provision would permit a board member, acting as a parent, to contest his or her child's academic grade or discipline.)

CODE OF ETHICS

In addition, the School Ethics Act requires school board members to abide by the following Code of Ethics for School Board Members:

- a. I will uphold and enforce all laws, rules and regulations of the State Board of Education and court orders pertaining to schools. Desired changes shall be brought about only through legal and ethical procedures.
- b. I will make decisions in terms of the educational welfare of children and will seek to develop and maintain public schools that meet the individual needs of all children regardless of their ability, race, creed, sex, or social standing.
- c. I will confine my board action to policy making, planning, and appraisal, and I will help to frame policies and plans only after

the board has consulted those who will be affected by them.

- d. I will carry out my responsibility, not to administer the schools, but together with my fellow board members, to see that they are well run.
- e. I will recognize that authority rests with the board of education and will make no personal promises nor take any private action that may compromise the board.
- f. I will refuse to surrender my independent judgment to special interest or partisan political groups or to use the schools for personal gain or for the gain of friends.
- g. I will hold confidential all matters pertaining to the schools which, if disclosed, would needlessly injure individuals or the schools. In all other matters, I will provide accurate information and, in concert with my fellow board members, interpret to the staff the aspirations of the community for its schools.
- h. I will vote to appoint the best-qualified personnel available after consideration of the recommendation of the chief administrative officer.
- i. I will support and protect school personnel in proper performance of their duties.
- j. I will refer all complaints to the chief administrative officer and will act on the complaints at public meetings only after failure of an administrative solution.

TRAINING

The School Ethics Act requires all school board members to complete a training program conducted by the New Jersey School Boards Association on the skills and knowledge needed to serve as a board member. The School Ethics Act requires the training to be completed during the first year of the board member's first term in office and to include information regarding the New Jersey Quality Single Accountability Continuum (NJQSAC). Additionally, board members must attend training on school governance in each of the subsequent two years of the board member's first term in office, as well as an advanced training program on relevant changes to New Jersey school law within the first year of a board member's re-election or reappointment to an additional term. Also a board member must complete a training program on harassment, intimidation and bullying in the schools, within one year after being newly elected/appointed, or re-elected/reappointed. A board member is required to complete this program only once.

NJSBA provides this training through its Board Member Academy. For details on NJSBA's training programs, go to the "Training and Conferences" section of www.njsba.org or call (888) 88-NJSBA.



For details on NJSBA's training programs, go to the "Training and Conferences" section of www.njsba.org or call (888) 88-NJSBA.